

# WIRING THE *RCS-PRO-3* ESC with battery power & Phoenix PB9 sound.

**N.B. It is OK to swap outputs #1, #2, #3 & #4 to suit TX sticks.**

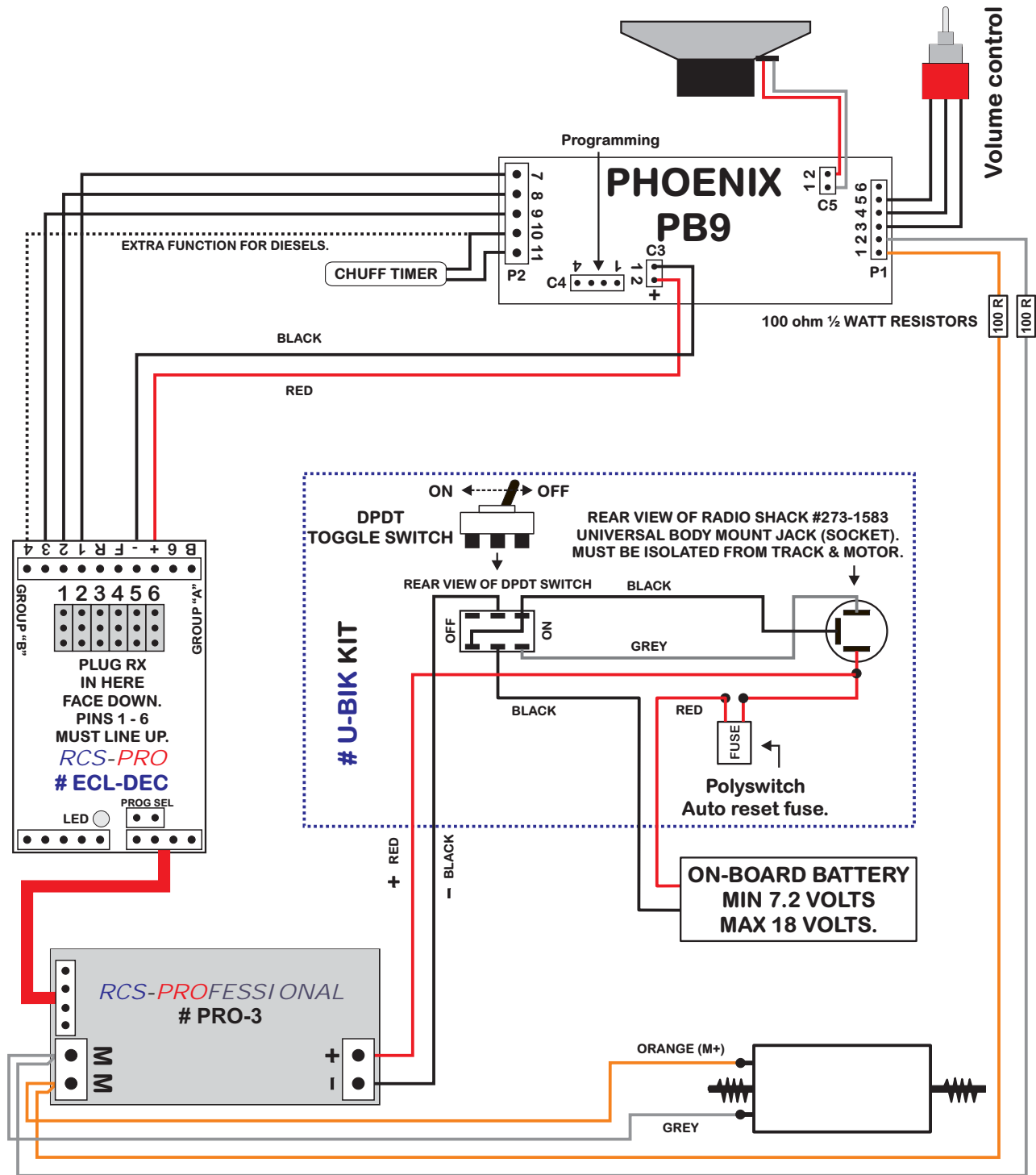

## CAUTION:

SPEKTRUM® R/C & PLANET TWISTER® R/C ARE GROUP "A" SYSTEMS.  
THEY MUST USE THE **PRO-Av1** PROGRAM.

HOBBY KING® R/C & E-SKY® R/C ARE GROUP "B" SYSTEMS.  
THEY MUST USE THE **PRO-Bv1** PROGRAM.