



PO BOX 1118 BAYSWATER, VIC 3153, AUSTRALIA
PHONE: INTERNATIONAL ++614 2902 9083
AUSTRALIA (04) 2902 9083 (03) 8685 8230
Web: <http://www.rcs-rc.com> Email: rcs@rcs-rc.com

RELAY-1A.

1 AMP RELAY KIT TO REVERSE
A CONSTANT VOLTAGE.

This 1 amp relay device is designed to change the polarity of a fixed voltage supply from 12 volts up to 24 volts.

It is intended for use with any brand of R/C throttle that has open collector transistors for switching lights such as the RCS **ELITE**, **EVOLUTION** and **BELTROL** ESC's.

The output polarity is governed by which lighting output is switched on at the R/C throttle.

INSTRUCTIONS FOR USE WITH ALL RCS ESC's

INSTALLATION.

You can mount the PCB with double stick tape. Do not allow metal objects to touch the rear of the PCB. Damage to the PCB may result.

USE WITH A MINIMUM OF !4 VOLT TRACTION BATTERIES.

Insert the Yellow wire only from the reverse light output terminal on the ELITE into the 3 way terminal marked R on the # RELAY-U. Likewise connect the Red/Black fused battery voltage into the terminals marked + (Red) & - (Black). The RELAY coil is off in the forward direction.

CONTROLLING LIGHTING OUTPUTS.

With regular incandescent bulbs use the supplied 1 amp diodes. For Diode lights use a suitable dropping resistor where shown.

Use the Red/Black track pickup cable with the USA Trains® plug with locking clip for version # 2. Plug into one of the two plugs without a locking clip coming from the USA Trains® PCB's.

OPERATION IS AUTOMATIC.

(1). When correctly wired the FRONT light will illuminate when first switched on. The Red wire is + positive when direction output is set to forwards. (Relay coil off).

(2). With USA Trains® locos the front headlight should come on at start up and the front marker lamp should be green. As you change direction to reverse the front light should go out and the front marker lamps should change colour to Red.

If not simply reverse the red/blackwires at the 2 way output terminal of the # RELAY.

The **RELAY-1A** can be used two different ways:

1. It is ideal for situations where you desire the front marker lamps to stay lit even though the front headlight is off.
2. Instead of rewiring USA Trains locos enough components are supplied that permit reversing the polarity of PCB's fitted in USA Trains locos, so the Red/Green marker lamps will now illuminate correctly.
3. Switching ON-OFF smoke units.

OR:

For greatly simplifying the Bachmann Shay R/C installation. Saves rewiring the Shay.

When making programming changes the lights will still blink correctly to acknowledge a change has been made.

The lights cannot be turned off completely by the TX handpiece.

To provide circuit protection we strongly suggest you fit a fuse in the controlled circuit.

TWO WAYS OF WIRING RELAY-1A FOR VERSION #1.

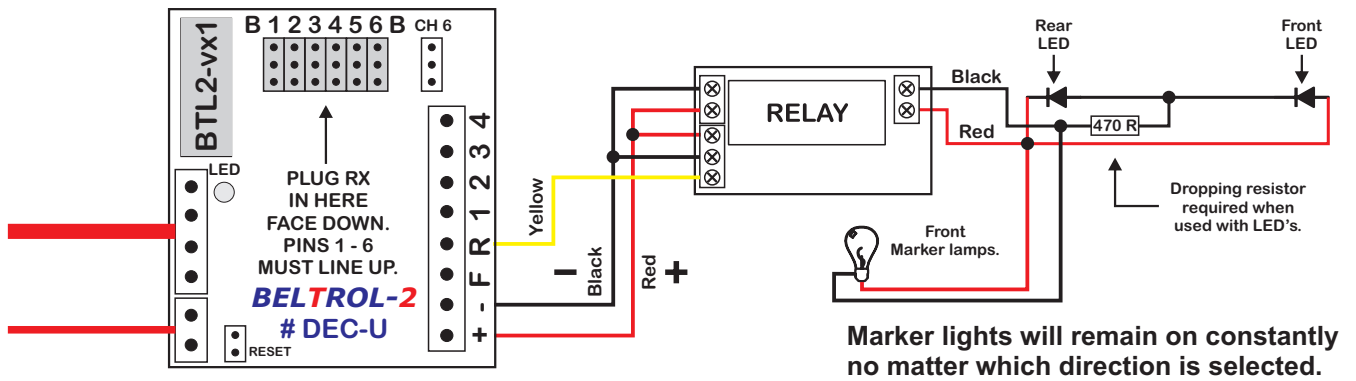
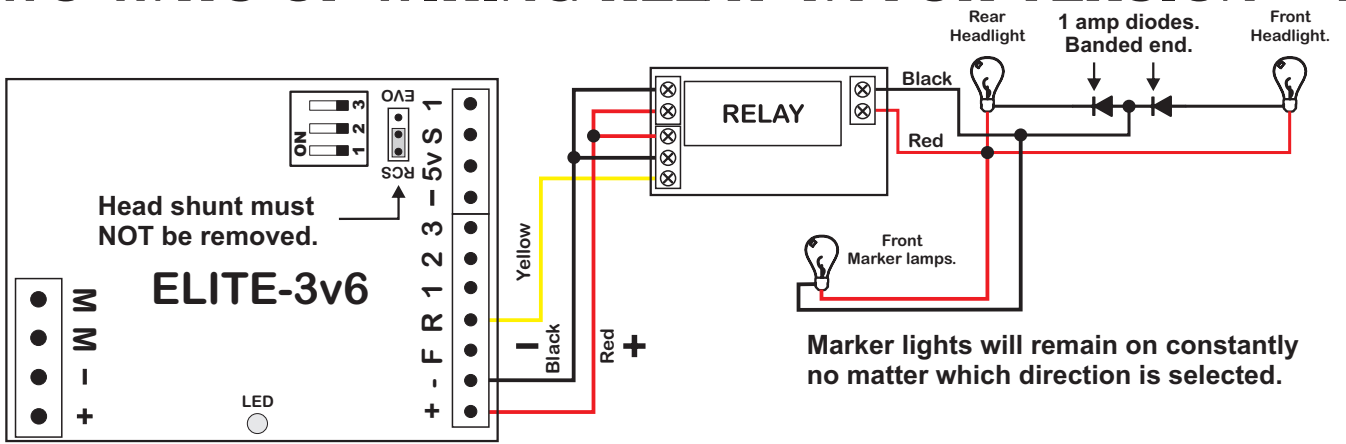

WIRING RELAY-1A FOR VERSION #2.

Use the Red/Black cable included with BIK-BGL kit to power the Bachmann® SHAY firebox.

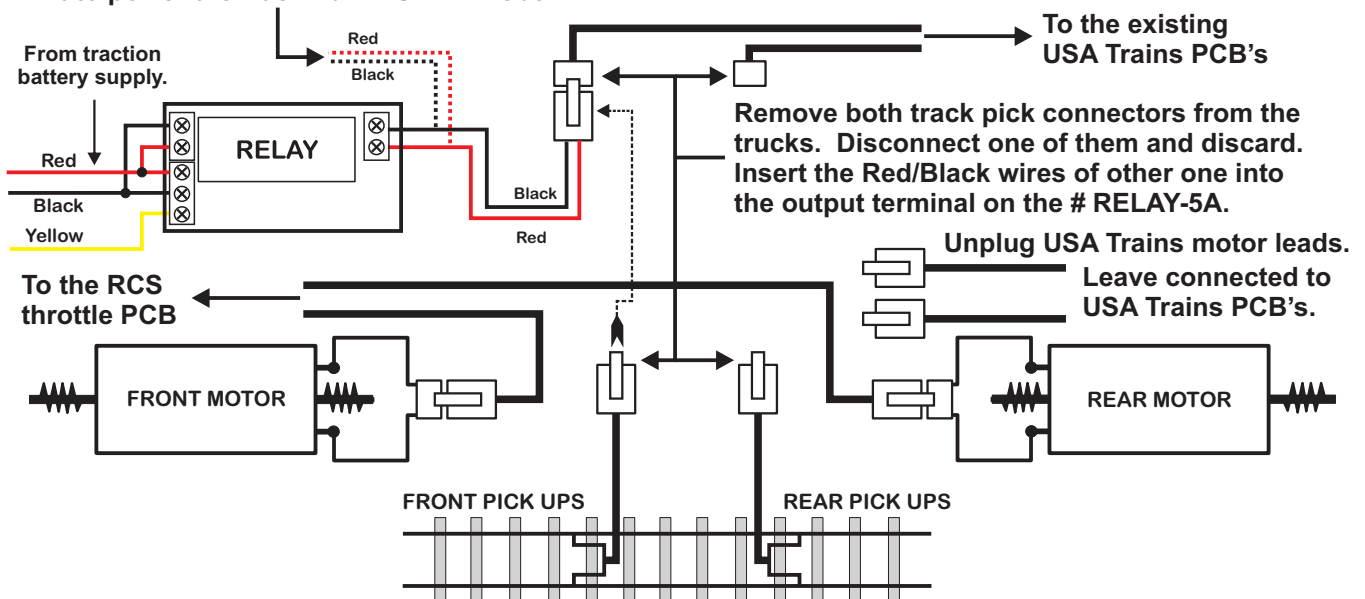

WIRING RELAY-1A AS AN SPDT SWITCH.

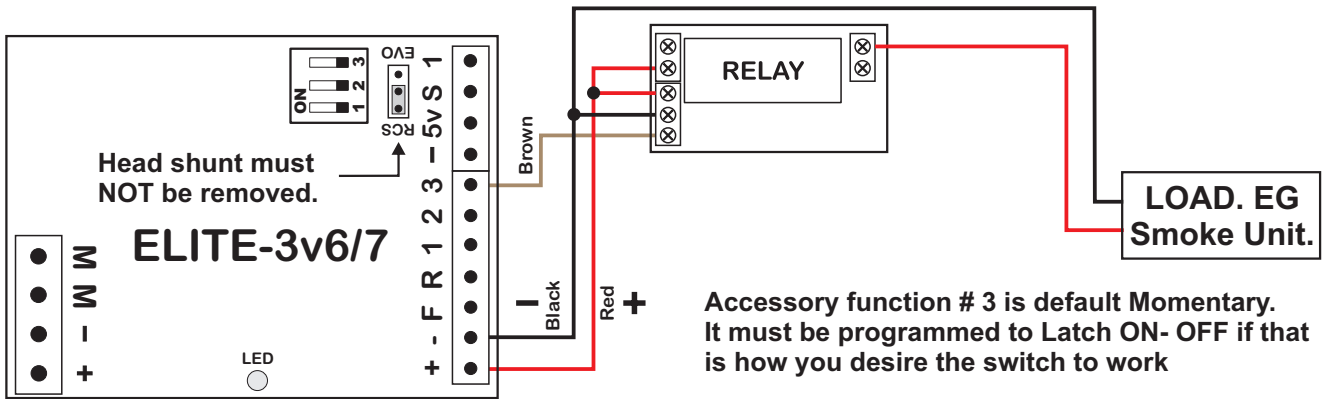

USING RELAY-1A AS AN SPDT WITH **BELTROL**.

